

**DeviceNet connection**

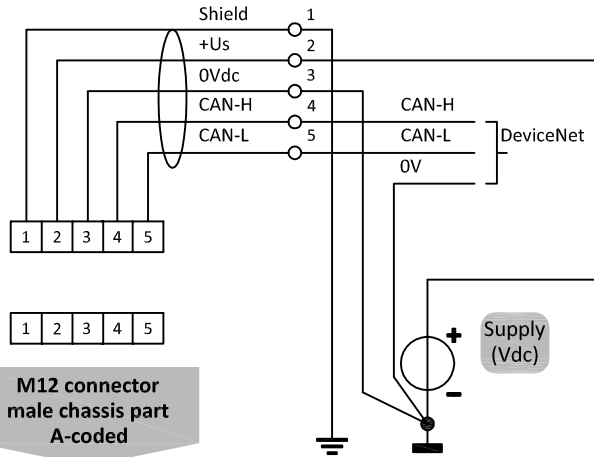

**Types**

(mini)CORI-FLOW

**Model key explanation**

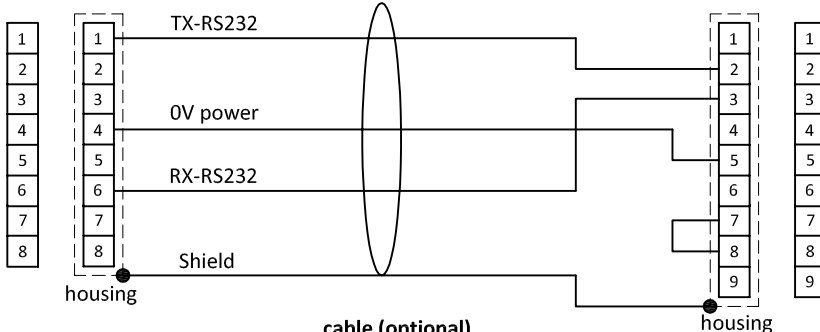
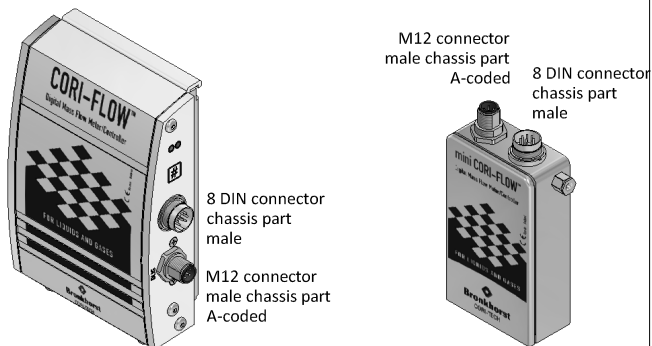
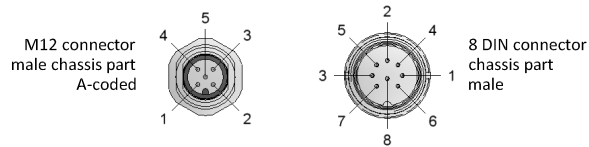
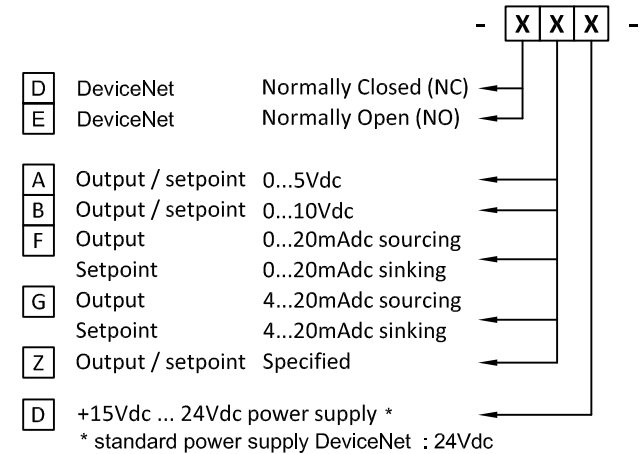

Note:  
When using a field bus or RS232, it is not possible to operate the instrument by using the setpoint signal of the analog 8 DIN connector without changing the value of parameter "control mode".  
See doc.nr. 9.17.023 for more details

Note:  
Do not connect an external valve to instruments, set as MFM.

Note:  
Powering a single instrument is possible by the 8 DIN connector.  
Please consult 9.16.044 for a connection diagram.